

Zhejiang Beijing Orient Vacuum  
Eletronic Co.ltd  
Intelligence Electronic SBU  
Address:No.C-1 Bridge Renming East  
Road,Shaoxing,Zhejiang CN

Tel:0086-575-88646699-9398  
Fax: 0086-575-88600754  
URL: <http://www.zec-vfd.com.cn>  
Email: [vfm@zec-vfd.com.cn](mailto:vfm@zec-vfd.com.cn)  
Postcode: 312000

**TO:**

**ADDR:**

**TEL:**

**FAX:**

## **VFD MODULE**

**MODEL: VFM202MDAR1-3**

**Conformed to RoHS requirements**

SPEC NO.		Div.	Date	Signature
REV.NO.	DATE	Written		
00	2004,2,6	Check		
01	2006,7,15	Approval		

## 1.0 SCOPE

This specification applies to VFD module (Model NO: VFM202MDAR1-3) manufactured by ZBOE.

## 2.0 GENERAL DESCRIPTION

- 2.1 This specification becomes effective after being approved by the purchaser.
- 2.2 When any conflict is found in the specification, appropriate action shall be taken upon agreement of both parties.
- 2.3 The expected necessary service parts should be arranged by the customer before the completion of production.

## 3.0 FEATURES

- 3.1 Two lines 5 x 8 dot matrix display, DC-DC/AC converter, and controller/driver circuitry.
- 3.2 One chip controller mounted on the module includes the character generator ROM (CG-ROM) of 240 5 x 8 characters.
- 3.3 The module can be configured for a Motorola M68-type parallel interface, an Intel I80-type parallel interface.
- 3.4 The luminance level of the VFD can be varied by setting two bits in the function set instruction, which are "don't care" bits for the module.
- 3.5 The module has a dual-port RAM that allows data and instructions to be sent to them continuously. Thus, the busy flag is always 0 and the host never has to read the busy flag bit to determine if the modules are busy.
- 3.6 High quality green vacuum fluorescent display provides an attractive and readable medium. Other colors can be achieved by simple wavelength filters.
- 3.7 The module has up to 8 user definable characters. (CG-RAM function)

STANDARD NAME:  <b>SPECIFICATION FOR APPROVAL</b>	DOCUMENT NUMBER:	REV:  00
	DATE PRINTED:	SHEET:  1 OF 21

## 4.0 SPECIFICATIONS

### 4.1 GENERAL SPECIFICATIONS

Number of characters (char x line)		20 x 2
Character configuration		5 x 8 dot matrix
Character height (mm)		8.95
Character width (mm)		3.85
Character pitch (mm)		1.3
Line pitch (mm)		0.6
Dot size (mm)	width	0.65
	height	0.97
Dot pitch (mm)	width	0.15
	height	0.17
Peak wavelength of illumination		Green (505 nm) x = 0.250, y = 0.440
Luminance (cd/m <sup>2</sup> / fL)	min.	350 / 102
	typ.	500 / 146

STANDARD NAME:

**SPECIFICATION FOR APPROVAL**

DOCUMENT NUMBER:

DATE PRINTED:

REV:

00

SHEET:

2 OF 21

## 4.2 MECHANICAL DRAWINGS

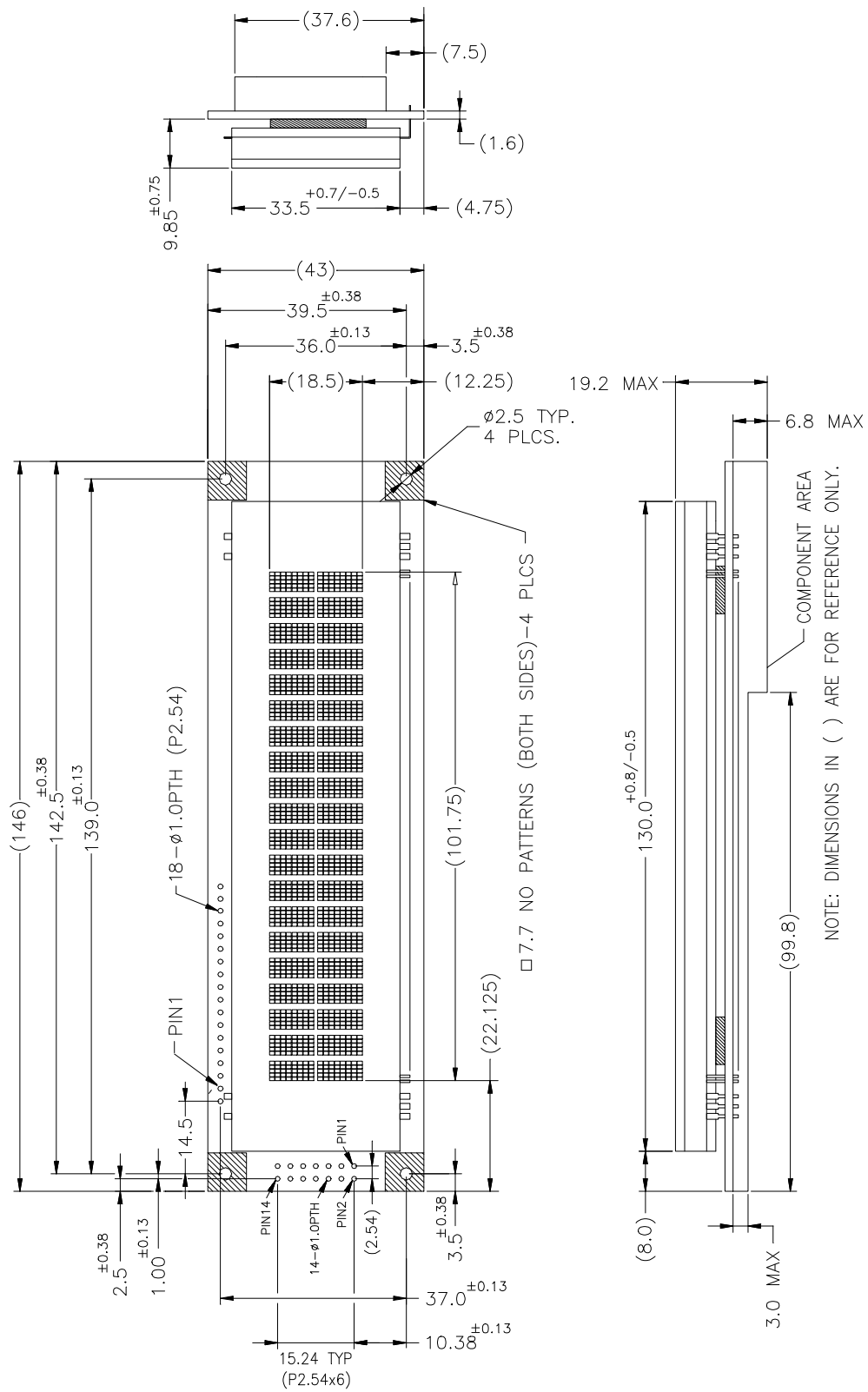

STANDARD NAME:

**SPECIFICATION FOR APPROVAL**

DOCUMENT NUMBER:

DATE PRINTED:

REV:

SHEET:

00

3 OF 21

### 4.3 SYSTEM BLOCK DIAGRAM

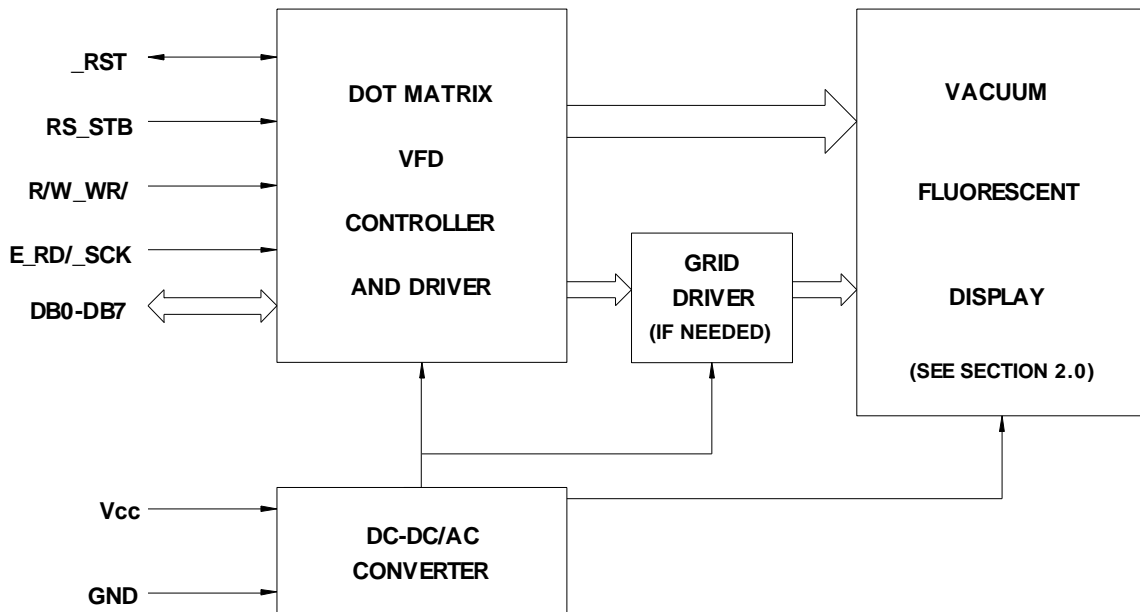

### 4.4 ENVIRONMENTAL SPECIFICATIONS

Item	Symbol	Min.	Max.	Unit	Comment
Operating temperature	Topr	-40	+85	°C	
Storage temperature	Tstg	-55	+85	°C	
Operating humidity	Hopr	20	85	%RH	Without condensation
Storage humidity	Hstg	20	90	%RH	Without condensation
Vibration	--	--	4	G	Total amplitude: 1.5mm Freq: 10 - 55 Hz sine wave Sweep time: 1 min./cycle Duration: 2 hrs./axis (X,Y,Z)
Shock	--	--	40	G	Duration: 11ms Waveform: half sine wave 3 times/axis (X,Y,Z,-X,-Y,-Z)

### 4.5 ABSOLUTE MAXIMUM SPECIFICATIONS

Item	Symbol	Min.	Max.	Unit
Supply voltage	V <sub>CC</sub>	-0.3	6.5	V
Input signal voltage	V <sub>IN</sub>	-0.3	V <sub>CC</sub> +0.3	V

STANDARD NAME:  <b>SPECIFICATION FOR APPROVAL</b>	DOCUMENT NUMBER:	REV:  00
	DATE PRINTED:	SHEET:  4 OF 21

#### 4.6 DC ELECTRICAL SPECIFICATIONS

Item	Symbol	Min.	Typ.	Max.	Unit
Supply voltage	$V_{CC}$	4.5	5.0	5.5	V
Supply current	$I_{CC}$	-	310	440	mA
High-level input voltage (see Note) (E,R/W,RD/,SCK,RST/)	$V_{IH1}$	$0.8*V_{CC}$	-	$V_{CC}$	V
Low-level input voltage (see Note) (E,R/W,RD/,SCK,RST/)	$V_{IL1}$	0.0	-	$0.2*V_{CC}$	V
High-level input voltage (see Note) (all inputs except E,R/W,RD/,SCK,RST/)	$V_{IH2}$	$0.7*V_{CC}$	-	$V_{CC}$	V
Low-level input voltage (see Note) (all inputs except E,R/W,RD/,SCK,RST/)	$V_{IL2}$	0.0	-	$0.3*V_{CC}$	V
High-level output voltage ( $I_{OH} = -0.1mA$ )	$V_{OH}$	$V_{CC}-0.5$	-	-	V
Low-level output voltage ( $I_{OL} = 0.1mA$ )	$V_{OL}$	-	-	0.5	V
Input current (see Note)	$I_I$	-500	-	1.0	$\mu A$

Note: A 10K ohm pull-up resistor is provided on each input for TTL compatibility.

#### 4.7 AC ELECTRICAL SPECIFICATIONS

##### 4.7.1 RESET TIMING

(See Figures 1 and 2)

Item	Symbol	Min.	Max.	Unit
$V_{CC}$ rise time	$t_{RVCC}$	-	10	ms
$V_{CC}$ off time	$t_{OFF}$	1	-	ms
Delay time after power-up reset	$t_{IRSTD}$	100	-	$\mu s$
Delay time after external reset	$t_{ERSTD}$	100	-	$\mu s$
RST/ pulse width low	$t_{RSTL}$	500	-	ns
Input signal fall time	$t_f$	-	15	ns
Input signal rise time	$t_r$	-	15	ns

Note: All timing is specified using 20% and 80% of  $V_{CC}$  as the reference points.

STANDARD NAME:

**SPECIFICATION FOR APPROVAL**

DOCUMENT NUMBER:

DATE PRINTED:

REV:

00

SHEET:

5 OF 21

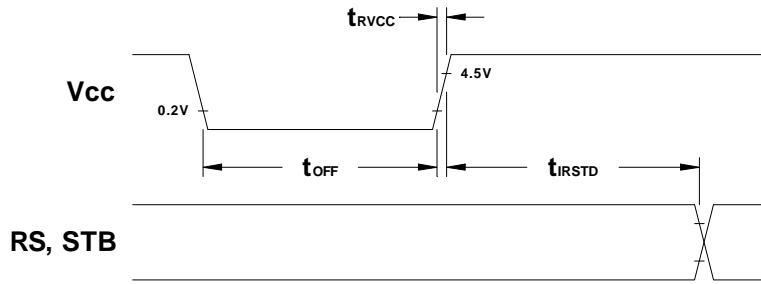

**Figure 1.** Power-up Internal Reset Timing

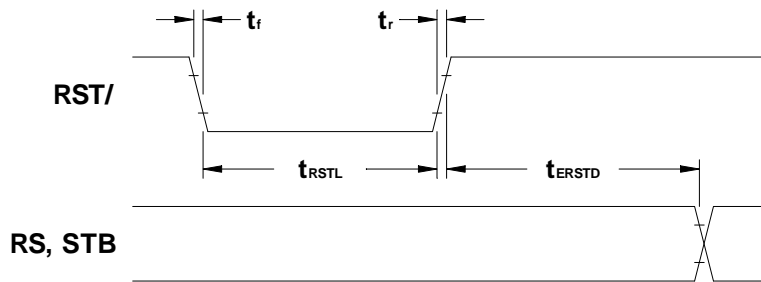

**Figure 2.** External Reset Timing

#### 4.7.2 MOTOROLA M68-TYPE PARALLEL INTERFACE TIMING

(See Figures 3 and 4)

Item	Symbol	Min.	Max.	Unit
RS, R/W setup time	$t_{AS}$	20	-	ns
RS, R/W hold time	$t_{AH}$	10	-	ns
Input signal rise time	$t_r$	-	15	ns
Input signal fall time	$t_f$	-	15	ns
E pulse width high	$PW_{EH}$	230	-	ns
E pulse width low	$PW_{EL}$	230	-	ns
Write data setup time	$t_{DS}$	80	-	ns
Write data hold time	$t_{DH}$	10	-	ns
E cycle time	$t_{CYCE}$	500	-	ns
Read data delay time	$t_{DD}$	-	160	ns
Read data hold time	$t_{DHR}$	5	-	ns

Note: All timing is specified using 20% and 80% of  $V_{CC}$  as the reference points.

STANDARD NAME:

**SPECIFICATION FOR APPROVAL**

DOCUMENT NUMBER:

DATE PRINTED:

REV:

00

SHEET:

6 OF 21

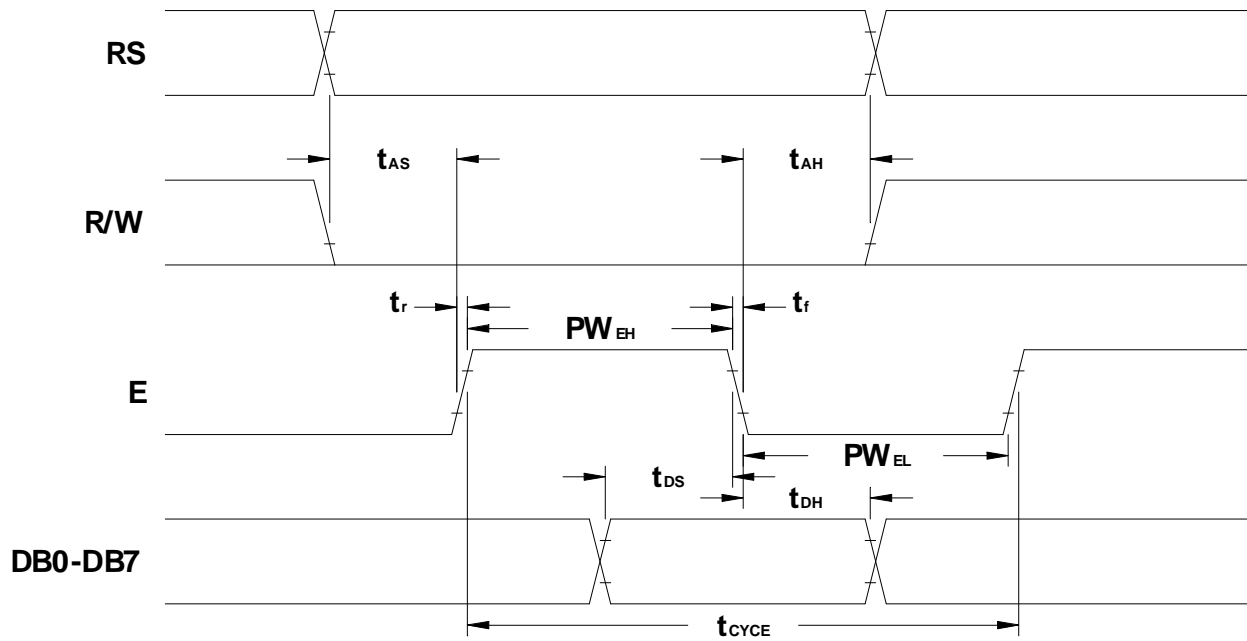

**Figure 3.** Motorola M68-Type Parallel Interface Write Cycle Timing

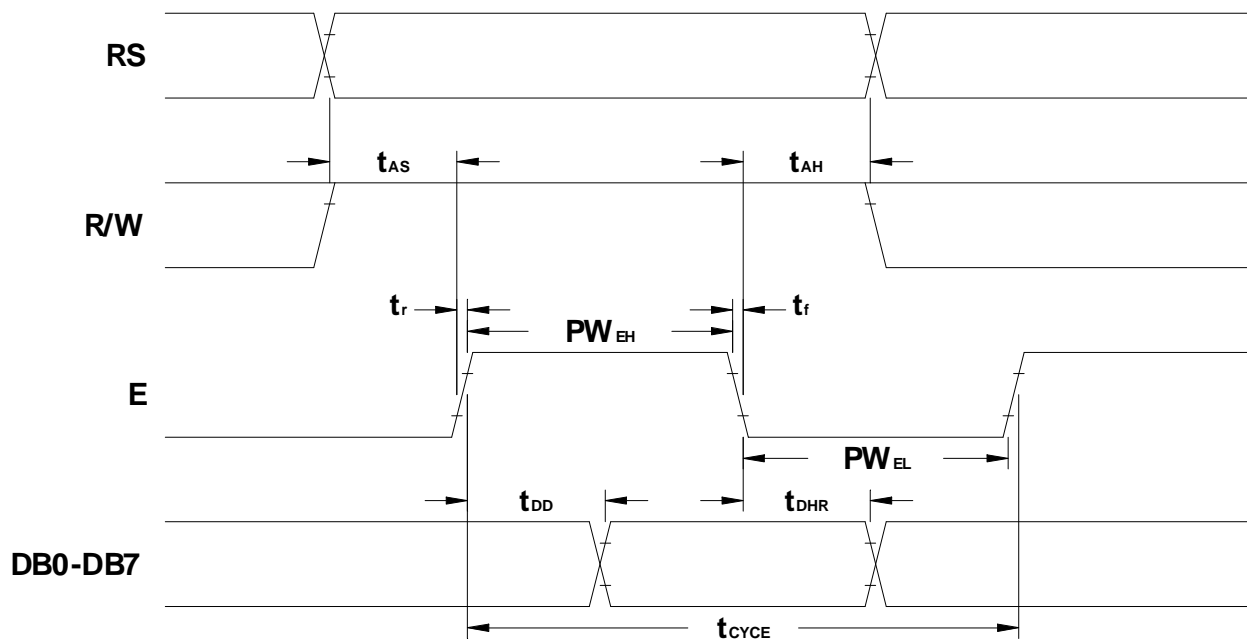

**Figure 4.** Motorola M68-Type Parallel Interface Read Cycle Timing

STANDARD NAME:

**SPECIFICATION FOR APPROVAL**

DOCUMENT NUMBER:

DATE PRINTED:

REV:

00

SHEET:

7 OF 21



### 4.7.3 INTEL I80-TYPE PARALLEL INTERFACE TIMING

(See Figures 5 and 6)

Item	Symbol	Min.	Max.	Unit
RS setup time	$t_{RSS}$	10	-	ns
RS hold time	$t_{RSH}$	10	-	ns
Input signal fall time	$t_f$	-	15	ns
Input signal rise time	$t_r$	-	15	ns
WR/ pulse width low	$t_{WRL}$	30	-	ns
WR/ pulse width high	$t_{WRH}$	100	-	ns
Write data setup time	$t_{DSi}$	30	-	ns
Write data hold time	$t_{DHi}$	10	-	ns
WR/ cycle time	$t_{CYCWR}$	200	-	ns
RD/ cycle time	$t_{CYCRD}$	200	-	ns
RD/ pulse width low	$t_{RDl}$	70	-	ns
RD/ pulse width high	$t_{RDh}$	100	-	ns
Read data delay time	$t_{DDi}$	-	70	ns
Read data hold time	$t_{DHRi}$	5	80	ns

Note: All timing is specified using 20% and 80% of  $V_{CC}$  as the reference points.

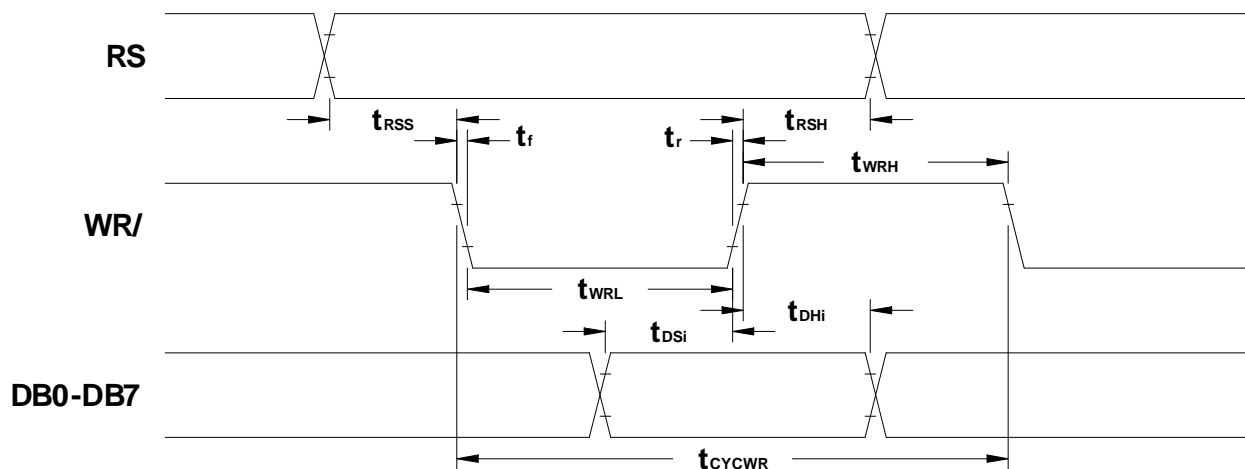

**Figure 5.** Intel I80-Type Parallel Interface Write Cycle Timing

STANDARD NAME:

**SPECIFICATION FOR APPROVAL**

DOCUMENT NUMBER:

DATE PRINTED:

REV:

00

SHEET:

8 OF 21

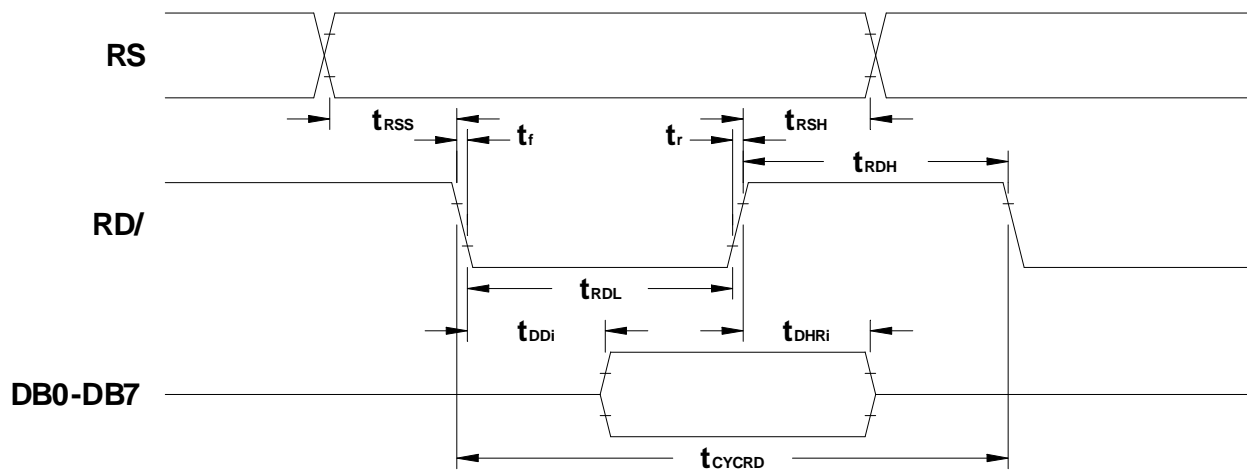

**Figure 6.** Intel I80-Type Parallel Interface Read Cycle Timing

STANDARD NAME: <b>SPECIFICATION FOR APPROVAL</b>	DOCUMENT NUMBER:	REV: 00
	DATE PRINTED:	SHEET: 9 OF 21

## 5.0 MODES OF OPERATION

The following modes of operation are selectable via jumpers (see section 9.0 Jumper Settings).

### 5.1 PARALLEL INTERFACE MODES

In the parallel interface mode, 8-bit instructions and data are sent between the host and the modules using either 4-bit nibbles or 8-bit bytes. Nibbles are transmitted high nibble first on DB4-DB7 (DB0-DB3 are ignored) whereas bytes are transmitted on DB0-DB7. The Register Select (RS) control signal is used to identify DB0-DB7 as an instruction (low) or data (high).

#### 5.1.1 MOTOROLA M68-TYPE MODE

This mode uses the Read/Write (R/W) and Enable (E) control signals to transfer information. Instructions/data are written to the module on the falling edge of E when R/W is low and are read from the module after the rising edge of E when R/W is high.

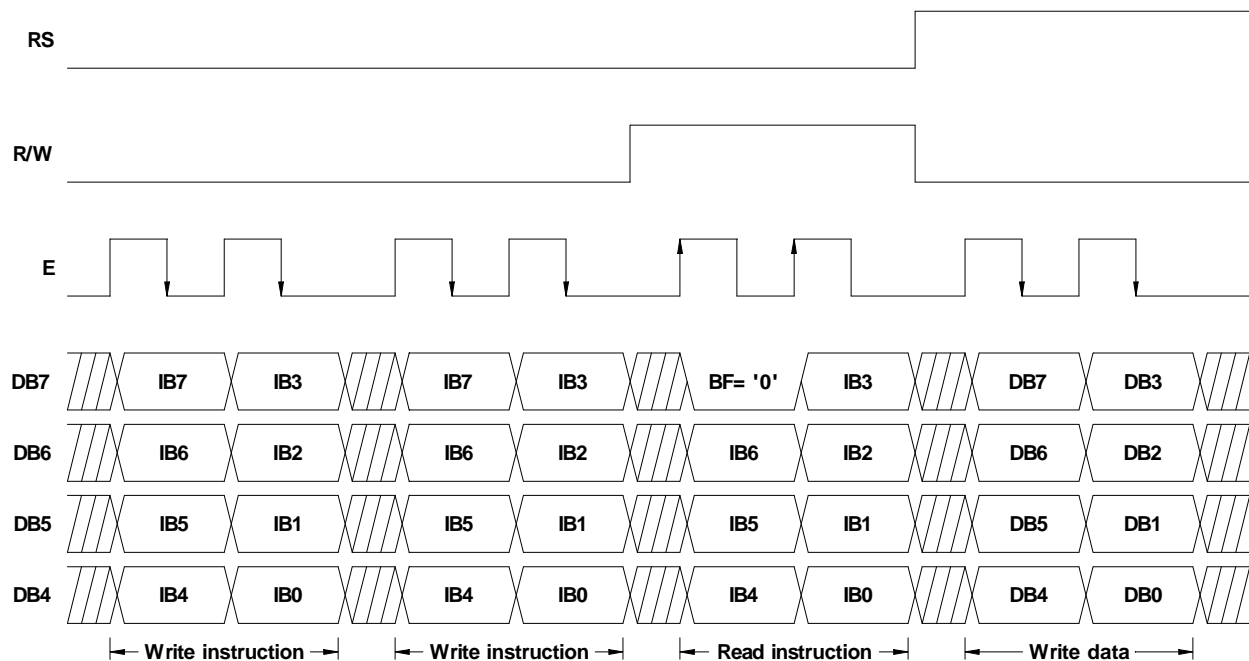

**Figure 9.** Typical 4-Bit Parallel Interface Sequence Using M68-Type Mode

STANDARD NAME:

**SPECIFICATION FOR APPROVAL**

DOCUMENT NUMBER:

DATE PRINTED:

REV:

00

SHEET:

10 OF 21

### 5.1.2 INTEL I80-TYPE MODE

This mode uses the Read (RD/) and Write (WR/) control signals to transfer information. Instructions/data are written to the module on the rising edge of WR/ and are read from the modules after the falling edge of RD/.

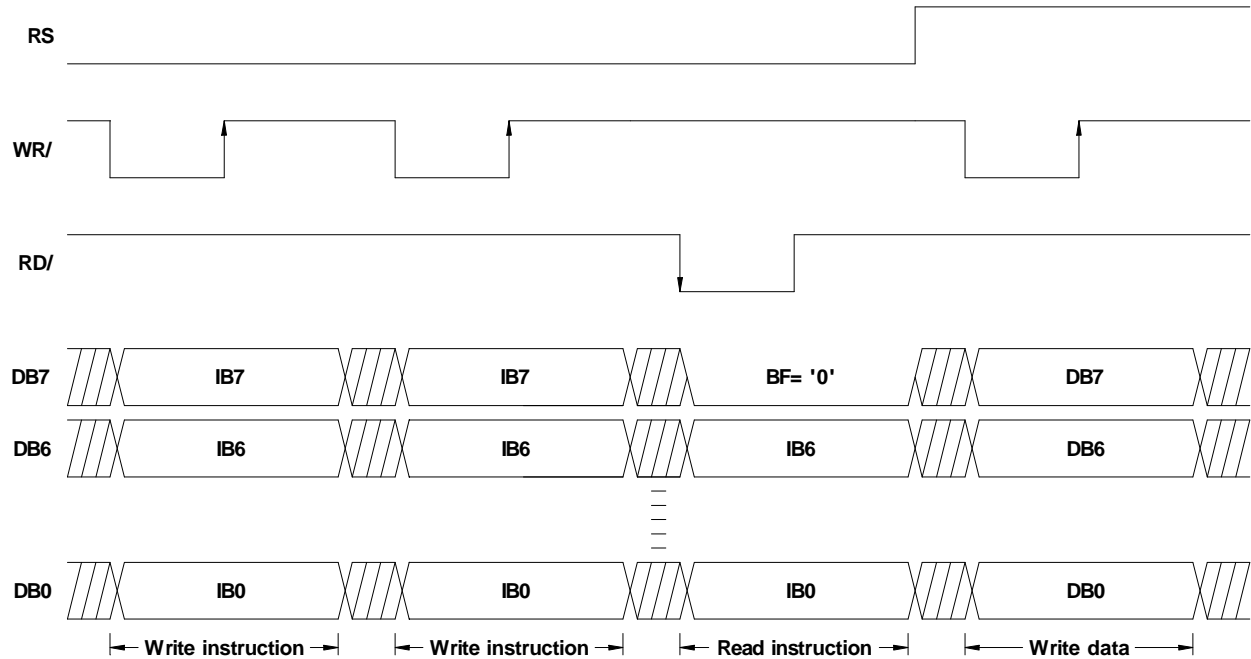

**Figure 10.** Typical 8-Bit Parallel Interface Sequence Using I80-Type Mode

### 5.2 RESET MODES

The module is reset automatically at power-up by an internal R-C circuit. However, an external reset mode can also be selected when using one of the parallel interface modes (this option is not available when using the synchronous serial interface mode). This mode allows the module to be reset by setting the Reset (RST/) input low.

STANDARD NAME:  <b>SPECIFICATION FOR APPROVAL</b>	DOCUMENT NUMBER:	REV:  00
	DATE PRINTED:	SHEET:  11 OF 21

# 6.0 CHARACTER FONT TABLE

UPPER NIBBLE / LOWER NIBBLE		0000	0001	0010	0011	0100	0101	0110	0111	1000	1001	1010	1011	1100	1101	1110	1111
0000	CG RAM (1)	!		0	o	P	\	F	A	E		-	o	e	o	P	
0001	CG RAM (2)	!	!	1	l	a	w	a	e	e		7	7	z	a	a	
0010	CG RAM (3)	!	"	2	B	b	r	A	E	r		7	7	x	e	e	
0011	CG RAM (4)	!	#	3	C	c	a	R	.	.		7	7	e	e	e	
0100	CG RAM (5)	!	\$	4	D	T	d	t	a	.		7	7	t	k	M	o
0101	CG RAM (6)	!	%	5	E	e	l	e	E	o	.	7	7	t	e	o	o
0110	CG RAM (7)	!	&	6	F	f	v	v	o	.		7	7	c	e	e	e
0111	CG RAM (8)	!	'	7	G	g	w	w	o	.		7	7	t	e	e	e
1000	CG RAM (1)	!	(	8	H	h	x	x	o	l	.	7	7	t	e	e	e
1001	CG RAM (2)	!	)	9	I	i	w	w	o	.		7	7	t	e	e	e
1010	CG RAM (3)	!	*	0	J	j	z	z	u	.		7	7	t	e	e	e
1011	CG RAM (4)	!	+	1	K	k	u	u	a	.		7	7	t	e	e	e
1100	CG RAM (5)	!	,	2	L	l	\	\	z	.		7	7	t	e	e	e
1101	CG RAM (6)	!	-	3	M	m	7	7	a	.		7	7	t	e	e	e
1110	CG RAM (7)	!	.	4	N	n	7	7	a	.		7	7	t	e	e	e
1111	CG RAM (8)	!	/	5	O	o	e	e	S	.		7	7	t	e	e	e

## 7.0 FUNCTIONAL DESCRIPTION

### 7.1 ADDRESS COUNTER (AC)

#### 7.1.1 SINGLE LINE DISPLAYS

The AC stores the address of the data being written to and read from DDRAM or CGRAM. The AC increments by 1 (overflows from 4FH to 00H) or decrements by 1 (underflows from 00H to 4FH) after each DDRAM access. The AC increments by 1 (overflows from 3FH to 00H) or decrements by 1 (underflows from 00H to 3FH) after each CGRAM access. When addressing DDRAM, the value in the AC also represents the cursor position.

#### 7.1.2 MULTIPLE LINE DISPLAYS

The AC stores the address of the data being written to and read from DDRAM or CGRAM. The AC increments by 1 (overflows from 27H to 40H and from 67H to 00H) or decrements by 1 (underflows from 40H to 27H and from 00H to 67H) after each DDRAM access. The AC increments by 1 (overflows from 3FH to 00H) or decrements by 1 (underflows from 00H to 3FH) after each CGRAM access. When addressing DDRAM, the value in the AC also represents the cursor position.

### 7.2 DISPLAY DATA RAM (DDRAM)

#### 7.2.1 SINGLE LINE DISPLAYS

The DDRAM stores the character code of each character being displayed on the VFD. Valid DDRAM addresses are 00H to 4FH. DDRAM not being used for display characters can be used as general purpose RAM. The tables below show the relationship between the DDRAM address and the character position on the VFD before and after a display shift (with the number of display lines set to 1).

#### 7.2.2 MULTIPLE LINE DISPLAYS

The DDRAM stores the character code of each character being displayed on the VFD. Valid DDRAM addresses are 00H to 27H and 40H to 67H. DDRAM not being used for display characters can be used as general purpose RAM. The tables below show the relationship between the DDRAM address and the character position on the VFD before and after a display shift (with the number of display lines set to 2).

STANDARD NAME:  <b>SPECIFICATION FOR APPROVAL</b>	DOCUMENT NUMBER:	REV:  00
	DATE PRINTED:	SHEET:  13 OF 21

### 7.3 DISPLAY SHIFT DETAIL

Relationship before a display shift (non-shifted):

	1	2	3	4	5	6	7	8	9	10	11	12	13	14	15	16	17	18	19	20
1	00	01	02	03	04	05	06	07	08	09	0A	0B	0C	0D	0E	0F	10	11	12	13
2	40	41	42	43	44	45	46	47	48	49	4A	4B	4C	4D	4E	4F	50	51	52	53

Relationship after a display shift to the left:

	1	2	3	4	5	6	7	8	9	10	11	12	13	14	15	16	17	18	19	20
1	01	02	03	04	05	06	07	08	09	0A	0B	0C	0D	0E	0F	10	11	12	13	14
2	41	42	43	44	45	46	47	48	49	4A	4B	4C	4D	4E	4F	50	51	52	53	54

Relationship after a display shift to the right:

	1	2	3	4	5	6	7	8	9	10	11	12	13	14	15	16	17	18	19	20
1	27	00	01	02	03	04	05	06	07	08	09	0A	0B	0C	0D	0E	0F	10	11	12
2	67	40	41	42	43	44	45	46	47	48	49	4A	4B	4C	4D	4E	4F	50	51	52

STANDARD NAME:

**SPECIFICATION FOR APPROVAL**

DOCUMENT NUMBER:

DATE PRINTED:

REV:

00

SHEET:

14 OF 21

## 7.4 CHARACTER GENERATOR RAM (CGRAM)

The CGRAM stores the pixel information (1 = pixel on, 0 = pixel off) for the eight user-definable 5x8 characters. Valid CGRAM addresses are 00H to 3FH. CGRAM not being used to define characters can be used as general purpose RAM (lower 5 bits only). Character codes 00H to 07H (or 08H to 0FH) are assigned to the user-definable characters (see section 5.0 Character Font Tables). The table below shows the relationship between the character codes, CGRAM addresses, and CGRAM data for each user-definable character.

Character code								CGRAM address					CGRAM data									
D7	D6	D5	D4	D3	D2	D1	D0	A5	A4	A3	A2	A1	A0	D7	D6	D5	D4	D3	D2	D1	D0	
0	0	0	0	X	0	0	0	0	0	0	0	0	0	X	X	X	0	1	1	1	1	CGRAM (1)
																		0	0	0	0	
																		0	0	0	1	
																		0	0	1	0	
																		0	0	1	0	
																		0	1	0	0	
																		0	0	0	0	
																		1	1	1	1	
																		0	0	0	0	
0	0	0	0	X	0	0	1	0	0	1	0	0	0	X	X	X	0	1	1	1	1	CGRAM (2)
																		0	0	0	0	
																		0	0	0	0	
																		0	0	0	0	
																		0	0	0	0	
																		1	1	1	0	
																		0	0	0	0	
																		0	0	0	0	
0	0	0	0	X	1	1	1	1	1	1	0	0	0	X	X	X	0	1	1	1	0	CGRAM (8)
																		0	0	0	1	
																		0	0	0	0	
																		0	0	0	0	
																		0	0	0	0	
																		0	0	0	0	
																		0	0	0	0	
																		0	0	0	1	

x = don't care

## 7.5 INSTRUCTIONS

Instruction	RS	R/W	DB7	DB6	DB5	DB4	DB3	DB2	DB1	DB0
Clear display	0	0	0	0	0	0	0	0	0	1
Cursor home	0	0	0	0	0	0	0	0	1	x
Entry mode set	0	0	0	0	0	0	0	1	I/D	S
Display on/off control	0	0	0	0	0	0	1	D	C	B
Cursor/display shift	0	0	0	0	0	1	S/C	R/L	x	x
Function set	0	0	0	0	1	DL	N	x	BR1	BR0
CGRAM address set	0	0	0	1	CGRAM address					
DDRAM address set	0	0	1	DDRAM address						
Address counter read	0	1	BF=0	AC contents						
DDRAM or CGRAM write	1	0	Write data							
DDRAM or CGRAM read	1	1	Read data							

x = don't care

STANDARD NAME:

**SPECIFICATION FOR APPROVAL**

DOCUMENT NUMBER:

DATE PRINTED:

REV:

00

SHEET:

15 OF 21



### 7.5.1 CLEAR DISPLAY

RS	R/W	DB7	DB6	DB5	DB4	DB3	DB2	DB1	DB0
0	0	0	0	0	0	0	0	0	1

This instruction clears the display (without affecting the contents of CGRAM) by performing the following:

- 1) Fills all DDRAM locations with character code 20H (character code for a space).
- 2) Sets the AC to DDRAM address 00H (i.e. sets cursor position to 00H).
- 3) Returns the display to the non-shifted position.
- 4) Sets the I/D bit to 1.

### 7.5.2 CURSOR HOME

RS	R/W	DB7	DB6	DB5	DB4	DB3	DB2	DB1	DB0
0	0	0	0	0	0	0	0	1	x

x = don't care

This instruction returns the cursor to the home position (without affecting the contents of DDRAM or CGRAM) by performing the following:

- 1) Sets the AC to DDRAM address 00H (i.e. sets cursor position to 00H).
- 2) Returns the display to the non-shifted position.

### 7.5.3 ENTRY MODE SET

RS	R/W	DB7	DB6	DB5	DB4	DB3	DB2	DB1	DB0
0	0	0	0	0	0	0	1	I/D	S

This instruction selects whether the AC (cursor position) increments or decrements after each DDRAM or CGRAM access and determines the direction the information on the display shifts after each DDRAM write. The instruction also enables or disables display shifts after each DDRAM write (information on the display does not shift after a DDRAM read or CGRAM access). DDRAM, CGRAM, and AC contents are not affected by this instruction.

I/D = 0: The AC decrements after each DDRAM or CGRAM access. If S = 1, the information on the display shifts to the right by one character position after each DDRAM write.

I/D = 1: The AC increments after each DDRAM or CGRAM access. If S = 1, the information on the display shifts to the left by one character position after each DDRAM write.

S = 0: The display shift function is disabled.

S = 1: The display shift function is enabled.

STANDARD NAME:

**SPECIFICATION FOR APPROVAL**

DOCUMENT NUMBER:

DATE PRINTED:

REV:

00

SHEET:

16 OF 21

## 7.5.4 DISPLAY ON/OFF CONTROL

RS	R/W	DB7	DB6	DB5	DB4	DB3	DB2	DB1	DB0
0	0	0	0	0	0	1	D	C	B

This instruction selects whether the display and cursor are on or off and selects whether or not the character at the current cursor position blinks. DDRAM, CGRAM, and AC contents are not affected by this instruction.

D = 0: The display is off (display blank).

D = 1: The display is on (contents of DDRAM displayed).

C = 0: The cursor is off.

C = 1: The cursor is on (8<sup>th</sup> row of pixels).

B = 0: The blinking character function is disabled.

B = 1: The blinking character function is enabled (a character with all pixels on will alternate with the character displayed at the current cursor position at about a 1Hz rate with a 50% duty cycle).

## 7.5.5 CURSOR/DISPLAY SHIFT

RS	R/W	DB7	DB6	DB5	DB4	DB3	DB2	DB1	DB0
0	0	0	0	0	1	S/C	R/L	x	x

x = don't care

This instruction increments or decrements the AC (cursor position) and shifts the information on the display one character position to the left or right without accessing DDRAM or CGRAM. DDRAM and CGRAM contents are not affected by this instruction. If the AC was addressing CGRAM prior to this instruction, the AC will be addressing DDRAM after this instruction. However, if the AC was addressing DDRAM prior to this instruction, the AC will still be addressing DDRAM after this instruction.

S/C	R/L	AC contents (cursor position)	Information on the display
0	0	Decrements by one	No change
0	1	Increments by one	No change
1	0	Decrements by one	Shifts one character position to the left
1	1	Increments by one	Shifts one character position to the right

STANDARD NAME:

**SPECIFICATION FOR APPROVAL**

DOCUMENT NUMBER:

DATE PRINTED:

REV:

00

SHEET:

17 OF 21

### 7.5.6 FUNCTION SET

RS	R/W	DB7	DB6	DB5	DB4	DB3	DB2	DB1	DB0
0	0	0	0	1	DL	N	x	BR1	BR0

x = don't care

This instruction sets the width of the data bus for the parallel interface modes, the number of display lines, and the luminance level (brightness) of the VFD. It must be the first command sent after any reset. DDRAM, CGRAM, and AC contents are not affected by this instruction.

DL = 0: Sets the data bus width for the parallel interface modes to 4-bit (DB7-DB4).

DL = 1: Sets the data bus width for the parallel interface modes to 8-bit (DB7-DB0).

N = 0: Sets the number of display lines to 1 (this setting is not recommended for multiple line displays).

N = 1: Sets the number of display lines to 2 (this setting is not recommended for single line displays).

BR1, BR0 = 0,0: Sets the luminance level to 100%.

0,1: Sets the luminance level to 75%.

1,0: Sets the luminance level to 50%.

1,1: Sets the luminance level to 25%.

### 7.5.7 CGRAM ADDRESS SET

RS	R/W	DB7	DB6	DB5	DB4	DB3	DB2	DB1	DB0
0	0	0	1	CGRAM address					

This instruction places the 6-bit CGRAM address specified by DB5-DB0 into the AC (cursor position). Subsequent data writes (reads) will be to (from) CGRAM. DDRAM and CGRAM contents are not affected by this instruction.

### 7.5.8 DDRAM ADDRESS SET

RS	R/W	DB7	DB6	DB5	DB4	DB3	DB2	DB1	DB0
0	0	1	DDRAM address						

This instruction places the 7-bit DDRAM address specified by DB6-DB0 into the AC (cursor position). Subsequent data writes (reads) will be to (from) DDRAM. DDRAM and CGRAM contents are not affected by this instruction.

STANDARD NAME:

**SPECIFICATION FOR APPROVAL**

DOCUMENT NUMBER:

DATE PRINTED:

REV:

00

SHEET:

18 OF 21

### 7.5.9 ADDRESS COUNTER READ

RS	R/W	DB7	DB6	DB5	DB4	DB3	DB2	DB1	DB0
0	1	BF=0	AC contents						

This instruction reads the current 7-bit address from the AC on DB6-DB0 and the busy flag (BF) bit (always 0) on DB7. DDRAM, CGRAM, and AC contents are not affected by this instruction. Because the BF is always 0, the host never has to read the BF bit to determine if the modules are busy before sending data or instructions. Therefore, data and instructions can be sent to the module continuously according to the E, WR/, and SCK cycle times specified in section 3.7 AC Timing Specifications. Due to this feature, the execution times for each instruction are not specified.

### 7.5.10 DDRAM OR CGRAM WRITE

RS	R/W	DB7	DB6	DB5	DB4	DB3	DB2	DB1	DB0
1	0	Write data							

This instruction writes the 8-bit data byte on DB7-DB0 into the DDRAM or CGRAM location addressed by the AC. The most recent DDRAM or CGRAM Address Set instruction determines whether the write is to DDRAM or CGRAM. This instruction also increments or decrements the AC and shifts the display according to the I/D and S bits set by the Entry Mode Set instruction.

### 7.5.11 DDRAM OR CGRAM READ

RS	R/W	DB7	DB6	DB5	DB4	DB3	DB2	DB1	DB0
1	1	Read data							

This instruction reads the 8-bit data byte from the DDRAM or CGRAM location addressed by the AC on DB7-DB0. The most recent DDRAM or CGRAM Address Set instruction determines whether the read is from DDRAM or CGRAM. This instruction also increments or decrements the AC and shifts the display according to the I/D and S bits set by the Entry Mode Set instruction. Before sending this instruction, a DDRAM or CGRAM Address Set instruction should be executed to set the AC to the desired DDRAM or CGRAM address to be read.

STANDARD NAME:

**SPECIFICATION FOR APPROVAL**

DOCUMENT NUMBER:

REV:

00

DATE PRINTED:

SHEET:

19 OF 21

## 7.6 RESET CONDITIONS

After either a power-up reset or an external reset, the module initializes to the following conditions:

- 1) All DDRAM locations are set to 20H (character code for a space).
- 2) The AC is set to DDRAM address 00H (i.e. sets cursor position to 00H).
- 3) The relationship between DDRAM addresses and character positions on the VFD is set to the non-shifted position.
- 4) Entry Mode Set instruction bits:
  - I/D = 1: The AC increments after each DDRAM or CGRAM access.
  - S = 0: The display shift function is disabled.
- 5) Display On/Off Control instruction bits:
  - D = 0: The display is off (display blank).
  - C = 0: The cursor is off.
  - B = 0: The blinking character function is disabled.
- 6) Function Set instruction bits:
  - DL = 1: Sets the data bus width for the parallel interface modes to 8-bit (DB7-DB0).
  - N = 1(0): Number of display lines set to 2 for multiple line displays (number of display lines set to 1 for single line displays).
  - BR1, BR0 = 0,0: Sets the luminance level to 100%.

Note that the function set command must be the first instruction sent to the module after any reset.

### 7.6.1 INITIALIZATION

The module can be initialized by using instructions if the module is not reset according to the reset timing detailed in Section 3.7.1 (Reset Timing). After any reset, the function set command must be the first instruction sent to the module.

STANDARD NAME:  <b>SPECIFICATION FOR APPROVAL</b>	DOCUMENT NUMBER:	REV:  00
	DATE PRINTED:	SHEET:  20 OF 21

## 8.0 CONNECTOR INTERFACE

Pin No.	Parallel (Intel)	Parallel (Motorola)	Pin No.	Parallel (Intel)	Parallel (Motorola)
1	GND	GND	2	V <sub>CC</sub>	V <sub>CC</sub>
3	NC or RST/	NC or RST/	4	RS	RS
5	WR/	R/W	6	RD/	E
7	DB0	DB0	8	DB1	DB1
9	DB2	DB2	10	DB3	DB3
11	DB4	DB4	12	DB5	DB5
13	DB6	DB6	14	DB7	DB7
15*	NC	NC	16*	NC	NC

NC = No Connection

\*If applicable.

## 8.1 CONNECTOR CONFIGURATION

Connector (if applicable)	Configuration
Berg P/N 67997-114 or equivalent	2 x 7

\*Also has holes that accept a 1 x 16 connector, Amp P/N 1-103747-6 or equivalent.

## 9.0 JUMPER SETTINGS

Mode	JP2	JP3	JP4	JP5	JP6	JP7
Parallel (Motorola)	(Note 1)	open	shorted	open	shorted	open
Parallel (Intel)	(Note 1)	open	shorted	open	open	shorted

Note 1: JP2 shorted (open) enables (disables) external reset mode.

STANDARD NAME:

**SPECIFICATION FOR APPROVAL**

DOCUMENT NUMBER:

DATE PRINTED:

REV:

00

SHEET:

21 OF 21