



深圳市一众显示科技有限公司

SHEN ZHEN TEAM SOURCE DISPLAY TECH. CO, LTD.

TFT-LCD Module Specification

Module NO.: TST070WVBE-32P

Version: V1.0

APPROVAL FOR SPECIFICATION

APPROVAL FOR SAMPLE

For Customer' s Acceptance:	
Approved by	Comment

Team Source Display:		
Presented by	Reviewed by	Organized by

Version No.	Date	Content	Remark
V1.0	2018-6-28	Initial Release	

CONTENTS

1 GENERAL CHARACTERISTICS..... - 3 -

2 PRODUCT DRAWINGS..... - 4 -

3 INTERFACE DESCRIPTION..... - 5 -

 3.1 LCM INTERFACE DESCRIPTION..... - 5 -

4 RGB TIMING CHARACTERISTICS..... - 6 -

5 ABSOLUTE MAXIMUM RATINGS..... - 7 -

6 ELECTRICAL CHARACTERISTICS..... - 7 -

7 BACKLIGHT CHARACTERISTICS..... - 7 -

8 LCD OPTICAL SPECIFICATIONS..... - 8 -

9 TOUCH PANEL SPECIFICATIONS..... - 10 -

10 RELIABILITY TEST..... - 10 -

11 SUGGESTIONS FOR USING LCD MODULES..... - 11 -

 11.1 HANDLING OF LCM..... - 11 -

 11.2 STORAGE..... - 11 -

1 General Characteristics

ITEM	Specification	Unit
LCD Type	a-Si TFT, Transmissive, Normally white, TN	-
LCD Size	7.0	inch
Resolution (W x H)	800x (RGB) × 480	pixel
LCM size	164.9(H) x 100(V) x 3.5(T)	mm
Active Area	154.08 (H) x 85.92 (V)	mm
Dot Pitch	0.0642(H) × 0.1790(V)	mm
Viewing Direction	12 o'clock	-
Gray Scale Inversion Direction	6 o'clock	-
Color Depth	16.7M	-
Pixel Arrangement	RGB-stripe	-
Backlight Type	21 LEDs, 60mA	-
Surface Luminance	360Min, 400TYP	cd/m ²
Surface Treatment	Clear, hardness: 3H	-
LCD Driver IC	EK9716BD/BD3 & EK73002ACGB	-
Interface Type	TTL (RGB-24bit)	-
Input Voltage	3.3	V
With/Without TP	With RTP	-
Weight	TBD	g

Note 1: RoHS compliant

Note 2: LCM weight tolerance: ± 5%.

2 Product drawings

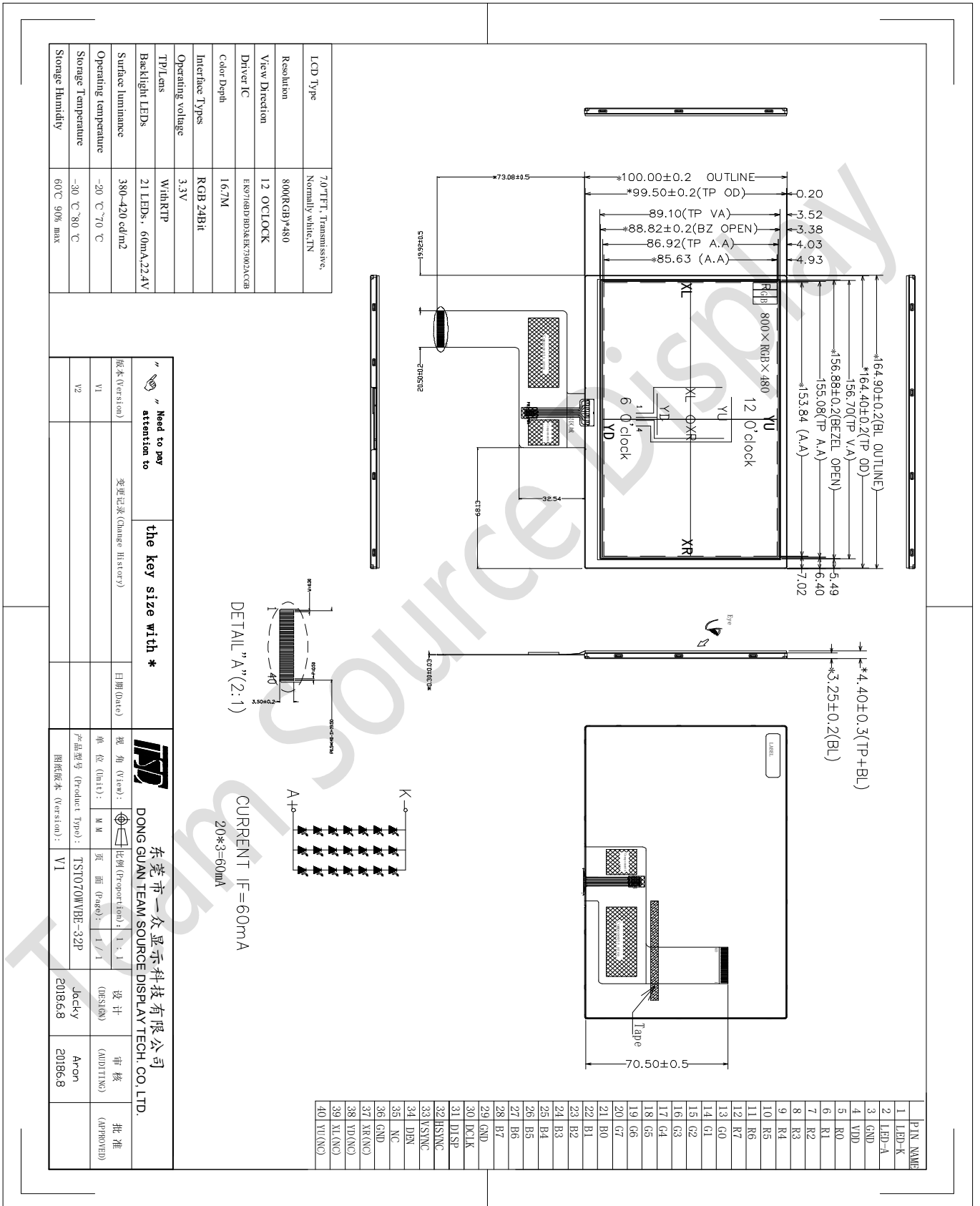

3 Interface description

3.1 LCM interface description

PIN NO.	Symbol	description
1	LED-K	Backlight K Cathode input pin.
2	LED-A	Backlight A Anode input pin.
3	GND	System Ground. (0V)
4	VDD	Power supply +3.3V
5~12	R0~R7	Red Data BUS
13~20	G0~G7	Green Data BUS
21~28	B0~B7	Blue Data BUS
29	GND	System Ground. (0V)
30	DCLK	Clock for input data. Data latched at rising/falling edge of this signal. Default is falling edge.
31	DISP	Standby mode control. (Normally pull high) DISP="L", enter standby mode for power saving. Timing controller and source driver will turn off, all outputs are Hi-Z. DISP="H", normal operation.
32	HSYNC	Horizontal sync input in digital parallel RGB. Negative polarity.
33	VSYNC	Vertical sync input in digital parallel RGB. Negative polarity.
34	DEN	Input data enable control. When DE mode, active High to enable data input. (Normally pull low)
35	NC	No connect
36	GND	System Ground. (0V)
37	XR/X+	Touch panel X right
38	YD/Y-	Touch panel Y down
39	XL/X-	Touch panel X left
40	YU/Y+	Touch panel Y UP

4 RGB Timing Characteristics

Vertical input timing

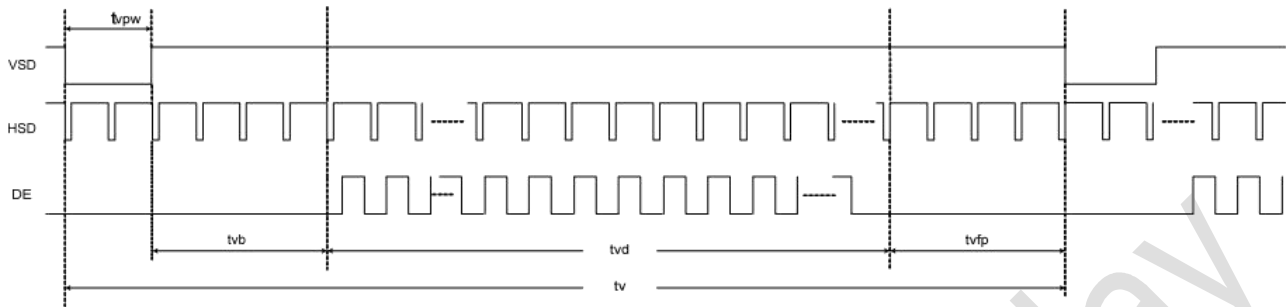

Horizontal input timing

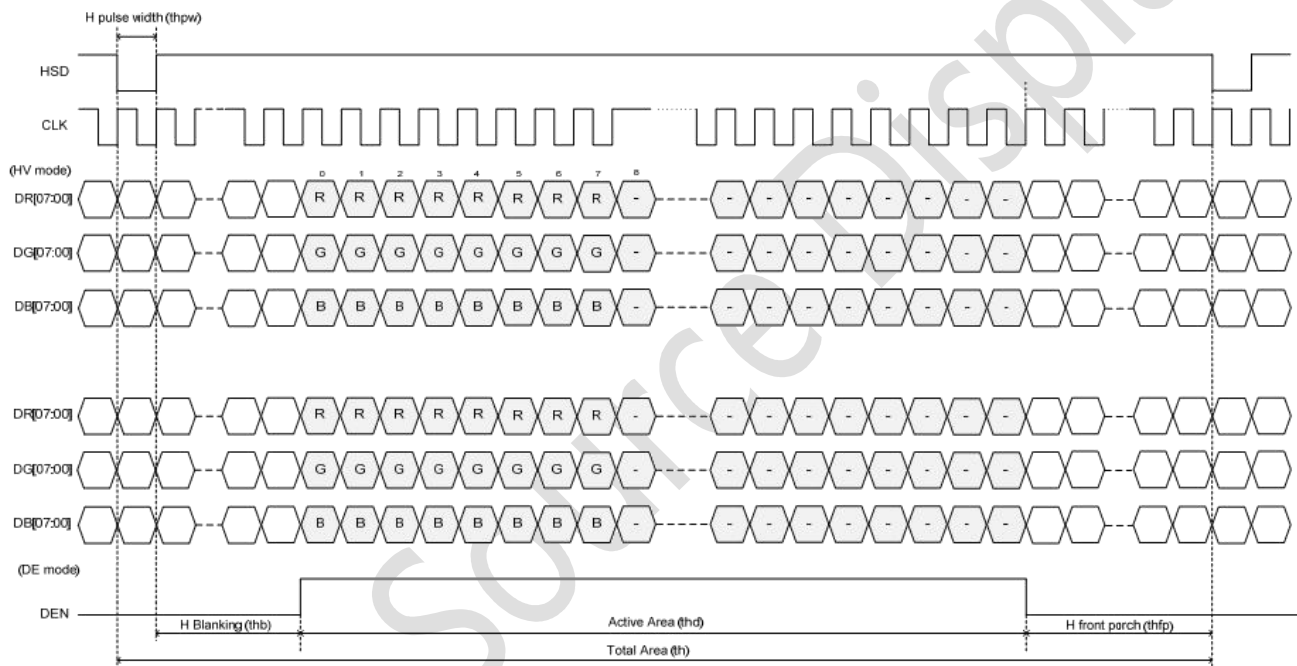

Horizontal input timing

Parameter	Symbol	Value			Unit	Note
Horizontal display area	t _{hd}	800			DCLK	
DCLK frequency	f _{clk}	Min.	Typ.	Max	MHz	
		20	33.3	50		
1 Horizontal Line	t _h	908	928	1088	DCLK	t _{hb} +t _{hpw} =88 DCLK is fixed.
HSD pulse width	t _{hpw}	1	48	87		
HSD Back Porch (Blanking)	t _{hb}	87	40	1		
HSD Front Porch	t _{hfp}	20	40	200		

Vertical input timing

Parameter	Symbol	Min.	Typ.	Max.	Unit	Note
Vertical display area	t _{vd}		480		H	
VSD period time	t _v	517	525	712	H	t _{pw} +t _{vb} =32H Is fixed
VSD pulse width	t _{pw}	1	1	3	H	
VSD Back Porch (Blanking)	t _{vb}	31	31	29	H	
VSD Front Porch	t _{vfp}	5	13	200	H	

5 Absolute Maximum Ratings

PARAMETER	SYMBOL	MIN	MAX	UNIT
Supply Voltage for Analog	VDD	-0.5	5.0	V
Operating Temperature	TOP	-20	70	° C
Storage Temperature	TST	-30	80	° C
Humidity	RH	-	90%(Max 60° C)	RH

6 Electrical Characteristics

PARAMETER	SYMBOL	MIN	TYP	MAX	UNIT
Analog operating voltage	VDD	3	3.3	3.6	V
Logic operating voltage	IOVDD	3	3.3	3.6	V
Input Current	IDD	-	TBD	-	mA
Input Voltage ' H ' level	VIH	0.7IOVCC	-	IOVCC	V
Input Voltage ' L ' level	VIL	GND	-	0.3IOVCC	

7 Backlight Characteristics

ITEM	SYMBOL	MIN	TYP	MAX	UNIT
Voltage for LED backlight	V _f	-	22.4	-	V
Current for LED backlight	I _f	-	60	-	mA
Power consumption	W _{bl}	-	1344	-	mW
Uniformity	Avg	80	-	-	%
LED Life Time	-	30000	40000	-	Hrs

Note:

1. The LED life time is defined as the module brightness decrease to 50% original brightness at Ta=25°C, 60%RH ±5 %.
2. The life time of LED will be reduced if LED is driven by high current, high ambient temperature and humidity conditions.
3. Typical operating life time is an estimated data.
4. Permanent damage to the device may occur if maximum values are exceeded or reverse voltage is loaded .Functional operation should be restricted to the conditions described under normal operating conditions.

8 LCD Optical specifications

Item	Symbol	Condition	Specification			Unit	Remark
			Min	Typ	Max		
Response time (By Quick)	Tr+Tf	$\theta = 0^\circ$	-	25	-	ms	Note 5
Contrast ratio	CR	$\theta = 0^\circ$	400	500	-		Note 2,6
Viewing angle	Top	$CR \geq 10$	70	75	-	Deg.	Note 2,6,7
	Bottom	$CR \geq 10$	65	70	-		
	Left	$CR \geq 10$	70	75	-		
	Right	$CR \geq 10$	70	75	-		
Color chromaticity (CIE1931)	Wx	$\theta = 0^\circ$	0.294	0.304	0.314		Note 3
	Wy		0.329	0.339	0.349		
	Rx		0.586	0.601	0.616		
	Ry		0.309	0.324	0.339		
	Gx		0.291	0.301	0.311		
	Gy		0.552	0.567	0.582		
	Bx		0.133	0.143	0.153		
	By		0.159	0.174	0.189		
NTSC			-	50%	-		Note 3
Transmittance	Trans		-	6.03%	-		Note 4

Note 1: Ambient temperature = 25°C.

Note 2: To be measured with a viewing cone of 2° by Topcon luminance meter BM-5A.

Note 3: To be measured with Otsuta chromaticity meter LCF-2100M, CF only measure under C light simulation.

Note 4: BOE shipping status is cell without polarizer. Transmittance of Specification is cell with polarizer. The tolerance of Transmittance is ±10%.

Note 5: Definition of response time:

The output signals of TRD-100 are measured when the input signals are changed to “White” (falling time) and from “White” to “Black” (rising time), respectively. The interval is between the 10% and 90% of amplitudes. Refer to figure as below.

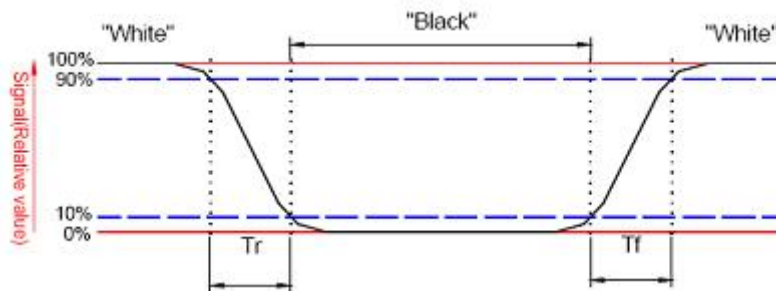

Note 6: Definition of contrast ratio:

Contrast ratio is calculated by the following formula.

$$\text{Contrast ratio (CR)} = \frac{\text{Brightness on the "white" state}}{\text{Brightness on the "black" state}}$$

Note 7: Definition of viewing angle

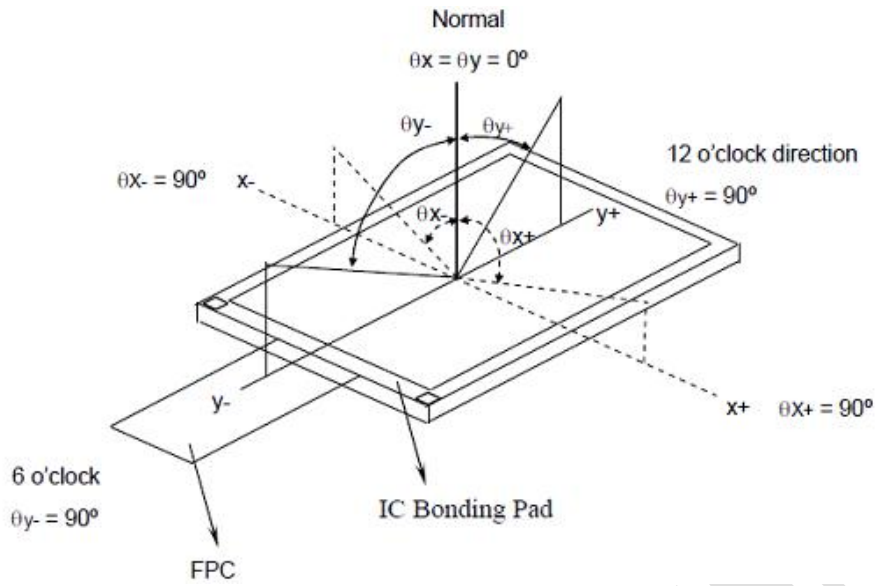

Note 8: Optical characteristic measurement setup.

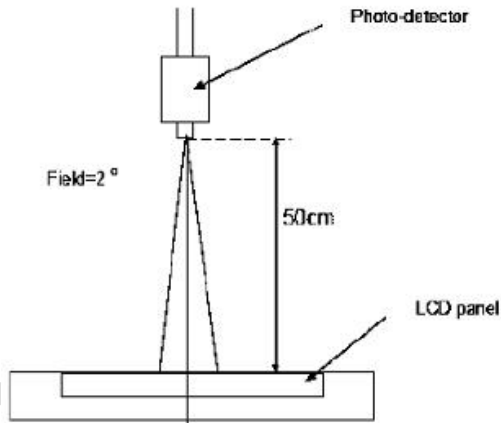

Note 9:

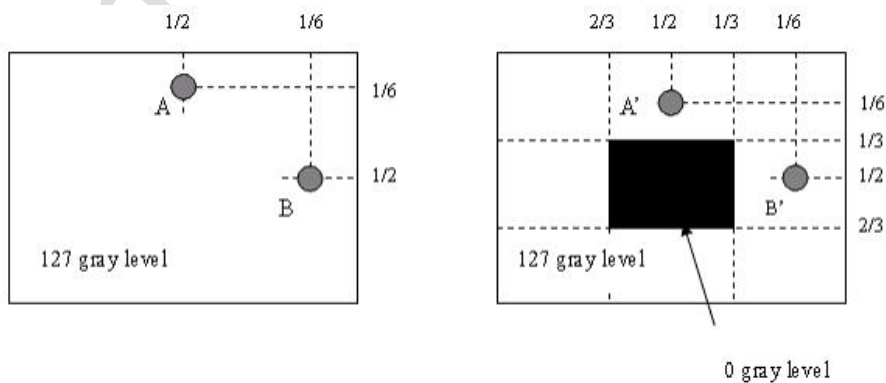

$|LA - LA'| / LA \times 100\% = 2\% \text{ max.}$, LA and LA' are brightness at location A and A'.
 $|LB - LB'| / LB \times 100\% = 2\% \text{ max.}$, LB and LB' are brightness at location B and B'.

9 Touch Panel specifications

ITEM	VALUE			UNIT	REMARK
	Min	Typ	Max		
Linearity	-	-	1.5	%	Analog X and Y directions
Terminal Resistance	350	-	1050	Ω	x
	100	-	500		y
Insulation Resistance	20	-	-	MΩ	DC 25V
Voltage	-	5	-	V	DC
Transparency	78	-	-	%	-
Operation Force	70	-	120	g	-
Endurance	1,000,000	-	-	Touches	100g Operation Force
	-	-	30,000	Slides	
Surface Hardness	3	-	-	H	-

10 RELIABILITY TEST

NO.	TEST ITEM	TEST CONDITION	INSPECTION AFTER TEST
1	High Temperature Storage	80±2°C/96 hours	Inspection after 2~4 hours storage at room temperature and humidity. The condensation is not accepted. The sample shall be free from defects: 1. Air bubble in the LCD 2. Seal leak 3. Non-display 4. Missing segments 5. Glass crack
2	Low Temperature Storage	-30±2°C/96 hours	
3	High Temperature Operating	70±2°C/96 hours	
4	Low Temperature Operating	-20±2°C/96 hours	
5	Temperature Cycle	-30±2°C ~ 25~ 80± 2°C × 10 cycles (30 min.) (5min.) (30min.)	
6	Damp Proof Test	60°C ±5°C × 90%RH/96 hours	
7	Vibration Test	Frequency 10Hz~55Hz Stroke: 1.5mm Sweep: 10Hz~150 Hz~10Hz 2 hours For each direction of X, Y, Z	
8	Shock Test	Half-sine, wave, 300m/s	
9	Packing Drop Test	Height: 80 cm 1 corner, concrete floor	
10	Electrostatic Discharge Test	C=150pF, R=330 Ω Air: ±8KV 150pF/330Ω 30 times Contact: ±4KV,20 times	

11 Suggestions for using LCD modules

11.1 Handling of LCM

1. The LCD screen is made of glass. Don't give excessive external shock, or drop from a high place.
2. If the LCD screen is damaged and the liquid crystal leaks out, do not lick and swallow. When the liquid is attach to your hand, skin, cloth etc, wash it off by using soap and water thoroughly and immediately.
3. Don't apply excessive force on the surface of the LCM.
4. If the surface is contaminated, clean it with soft cloth. If the LCM is severely contaminated, use Isopropyl alcohol/Ethyl alcohol to clean. Other solvents may damage the polarizer. The following solvents is especially prohibited: water , ketone Aromatic solvents etc.
5. Exercise care to minimize corrosion of the electrode. Corrosion of the electrodes is accelerated by water droplets, moisture condensation or a current flow in a high-humidity environment.
6. Install the LCD Module by using the mounting holes. When mounting the LCD module make sure it is free of twisting, warping and distortion. In particular, do not forcibly pull or bend the I/O cable or the backlight cable.
7. Don't disassemble the LCM.
8. To prevent destruction of the elements by static electricity, be careful to maintain an optimum work environment.
 - Be sure to ground the body when handling the LCD modules.
 - Tools required for assembling, such as soldering irons, must be properly grounded.
 - To reduce the amount of static electricity generated, do not conduct assembling and other work under dry conditions.
 - The LCD module is coated with a film to protect the display surface. Exercise care when peeling off this protective film since static electricity may be generated.
9. Do not alter, modify or change the the shape of the tab on the metal frame.
10. Do not make extra holes on the printed circuit board, modify its shape or change the positions of components to be attached.
11. Do not damage or modify the pattern writing on the printed circuit board.
12. Absolutely do not modify the zebra rubber strip (conductive rubber) or heat seal connector
13. Except for soldering the interface, do not make any alterations or modifications with a soldering iron.
14. Do not drop, bend or twist LCM.

11.2 Storage

1. Store in an ambient temperature of 5 to 45 C, and in a relative humidity of 40% to 60%. Don't expose to sunlight or fluorescent light.
2. Storage in a clean environment, free from dust, active gas, and solvent.
3. Store in antistatic container.

